

# NC7WV07 TinyLogic® ULP-A Dual Buffer (Open Drain Output)

## Features

- 0.9V to 3.6V  $V_{CC}$  supply operation
- 3.6V overvoltage tolerant I/O's at  $V_{CC}$  from 0.9V to 3.6V
- Extremely High Speed  $t_{PD}$ 
  - 1.0 ns typ for 2.7V to 3.6V  $V_{CC}$
  - 1.2 ns typ for 2.3V to 2.7V  $V_{CC}$
  - 2.0 ns typ for 1.65V to 1.95V  $V_{CC}$
  - 3.2 ns typ for 1.4V to 1.6V  $V_{CC}$
  - 6.0 ns typ for 1.1V to 1.3V  $V_{CC}$
  - 13.0 ns typ for 0.9V  $V_{CC}$
- Power-Off high impedance inputs and outputs
- High Static Drive ( $I_{OH}/I_{OL}$ )
  - $\pm 24$  mA @ 3.00V  $V_{CC}$
  - $\pm 18$  mA @ 2.30V  $V_{CC}$
  - $\pm 6$  mA @ 1.65V  $V_{CC}$
  - $\pm 4$  mA @ 1.4V  $V_{CC}$
  - $\pm 2$  mA @ 1.1V  $V_{CC}$
  - $\pm 0.1$  mA @ 0.9V  $V_{CC}$
- Uses patented Quiet Series™ noise/EMI reduction circuitry
- Ultra small MicroPak™ leadfree package
- Ultra low dynamic power

## General Description

The NC7WV07 is a dual buffer with open drain output from Fairchild's Ultra Low Power-A series of TinyLogic®. ULP-A is ideal for applications that require extreme high speed, high drive and low power. This product is designed for a wide low voltage operating range (0.9V to 3.6V  $V_{CC}$ ) and applications that require more drive and speed than the TinyLogic ULP series, but still offer best in class low power operation.

The NC7WV07 is uniquely designed for optimized power and speed, and is fabricated with an advanced CMOS technology to achieve high-speed operation while maintaining low CMOS power dissipation.

## Ordering Information

Order Number	Package Number	Package Code Top Mark	Package Description	Supplied As
NC7WV07P6X	MAA06A	V07	6-Lead SC70, EIAJ SC88, 1.25mm Wide	3k Units on Tape and Reel
NC7WV07L6X	MAC06A	BC	6-Lead MicroPak, 1.0mm Wide	5k Units on Tape and Reel

## Battery Life vs. $V_{CC}$ Supply Voltage

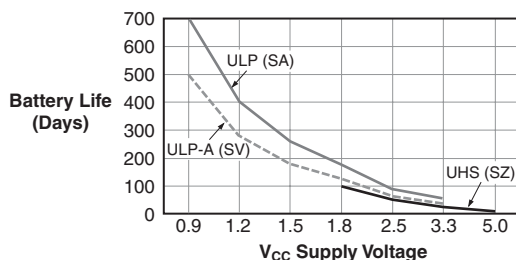

TinyLogic ULP and ULP-A with up to 50% less power consumption can extend your battery life significantly.

$$\text{Battery Life} = (V_{\text{battery}} \cdot I_{\text{battery}} \cdot 0.9) / (P_{\text{device}}) / 24\text{hrs/day}$$

$$\text{Where, } P_{\text{device}} = (I_{CC} \cdot V_{CC}) + (C_{PD} + C_L) \cdot V_{CC}^2 \cdot f$$

Assumes ideal 3.6V Lithium Ion battery with current rating of 900mAh and derated 90% and device frequency at 10MHz, with  $C_L = 15\text{pF}$  load.

TinyLogic® is a registered trademark of Fairchild Semiconductor Corporation.  
MicroPak™ and Quiet Series™ are trademarks of Fairchild Semiconductor Corporation.

## Logic Symbol

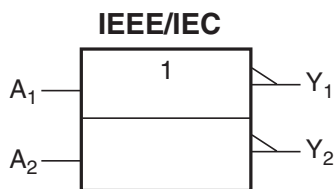

## Connection Diagrams

### Pin Assignment for SC70

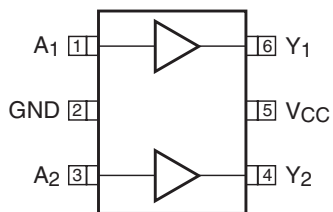

(Top View)

### Pin One Orientation Diagram

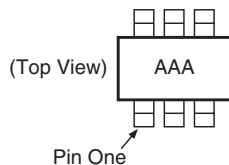

AAA represents Product Code Top Mark – see ordering code

**Note:** Orientation of Top Mark determines Pin One location. Read the Top Product Code Mark left to right, Pin One is the lower left pin (see diagram).

### Pad Assignments for MicroPak

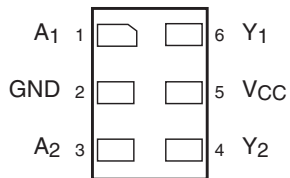

(Top Through View)

## Pin Descriptions

Pin Name	Description
A <sub>1</sub> , A <sub>2</sub>	Data Inputs
Y <sub>1</sub> , Y <sub>2</sub>	Outputs

## Function Table

$$Y = A$$

Input	Output
A	Y
L	L
H	H

H = HIGH Logic Level    L = LOW Logic Level

## Absolute Maximum Ratings

The “Absolute Maximum Ratings” are those values beyond which the safety of the device cannot be guaranteed. The device should not be operated at these limits. The parametric values defined in the Electrical Characteristics tables are not guaranteed at the absolute maximum ratings. The “Recommended Operating Conditions” table will define the conditions for actual device operation.

Symbol	Parameter	Rating
$V_{CC}$	Supply Voltage	-0.5V to +4.6V
$V_{IN}$	DC Input Voltage	-0.5V to +4.6V
$V_{OUT}$	DC Output Voltage HIGH or LOW State <sup>(1)</sup> $V_{CC} = 0V$	-0.5V to $V_{CC} + 0.5V$ -0.5V to +4.6V
$I_{IK}$	DC Input Diode Current @ $V_{IN} < 0V$	±50mA
$I_{OK}$	DC Output Diode Current $V_{OUT} < 0V$ $V_{OUT} > V_{CC}$	-50mA +50mA
$I_{OH}/I_{OL}$	DC Output Source/Sink Current	±50mA
$I_{CC}$ or Ground	DC $V_{CC}$ or Ground Current per Supply Pin	±50mA
$T_{STG}$	Storage Temperature Range	-65°C to +150°C

## Recommended Operating Conditions<sup>(2)</sup>

Symbol	Parameter	Rating
$V_{CC}$	Supply Voltage	0.9V to 3.6V
$V_{IN}$	Input Voltage	0V to 3.6V
$V_{OUT}$	Output Voltage $V_{CC} = 0.0V$ HIGH or LOW State	0V to 3.6V 0V to $V_{CC}$
$I_{OH}/I_{OL}$	Output Current in $I_{OH}/I_{OL}$ $V_{CC} = 3.0V$ to 3.6V $V_{CC} = 2.3V$ to 2.7V $V_{CC} = 1.65V$ to 1.95V $V_{CC} = 1.4V$ to 1.6V $V_{CC} = 1.1V$ to 1.3V $V_{CC} = 0.9V$	±24mA ±18mA ±6mA ±4mA ±2mA ±0.1mA
$T_A$	Free Air Operating Temperature	-40°C to +85°C
$\Delta t/\Delta V$	Minimum Input Edge Rate @ $V_{IN} = 0.8V$ to 2.0V, $V_{CC} = 3.0V$	10ns/V

### Notes:

- $I_O$  Absolute Maximum Rating must be observed.
- Unused inputs must be held HIGH or LOW. They may not float.

### DC Electrical Characteristics

Symbol	Parameter	Conditions	V <sub>CC</sub> (V)	T <sub>A</sub> =				Units
				+25°C		-40°C to +85°C		
				Min.	Max.	Min.	Max.	
V <sub>IH</sub>	HIGH Level Input Voltage		0.90	0.65 x V <sub>CC</sub>	–	0.65 x V <sub>CC</sub>	–	V
			1.10 ≤ V <sub>CC</sub> ≤ 1.30	0.65 x V <sub>CC</sub>	–	0.65 x V <sub>CC</sub>	–	
			1.40 ≤ V <sub>CC</sub> ≤ 1.60	0.65 x V <sub>CC</sub>	–	0.65 x V <sub>CC</sub>	–	
			1.65 ≤ V <sub>CC</sub> ≤ 1.95	0.65 x V <sub>CC</sub>	–	0.65 x V <sub>CC</sub>	–	
			2.30 ≤ V <sub>CC</sub> < 2.70	1.6	–	1.6	–	
			2.70 ≤ V <sub>CC</sub> ≤ 3.60	2.0	–	2.0	–	
V <sub>IL</sub>	LOW Level Input Voltage		0.90	–	0.35 x V <sub>CC</sub>	–	0.35 x V <sub>CC</sub>	V
			1.10 ≤ V <sub>CC</sub> ≤ 1.30	–	0.35 x V <sub>CC</sub>	–	0.35 x V <sub>CC</sub>	
			1.40 ≤ V <sub>CC</sub> ≤ 1.60	–	0.35 x V <sub>CC</sub>	–	0.35 x V <sub>CC</sub>	
			1.65 ≤ V <sub>CC</sub> ≤ 1.95	–	0.35 x V <sub>CC</sub>	–	0.35 x V <sub>CC</sub>	
			2.30 ≤ V <sub>CC</sub> < 2.70	–	0.7	–	0.7	
			2.70 ≤ V <sub>CC</sub> ≤ 3.60	–	0.8	–	0.8	
V <sub>OL</sub>	LOW Level Output Voltage	I <sub>OL</sub> = 100µA	0.90	–	0.1	–	0.1	V
			1.10 ≤ V <sub>CC</sub> ≤ 1.30	–	0.1	–	0.1	
			1.40 ≤ V <sub>CC</sub> ≤ 1.60	–	0.2	–	0.2	
			1.65 ≤ V <sub>CC</sub> ≤ 1.95	–	0.2	–	0.2	
			2.30 ≤ V <sub>CC</sub> < 2.70	–	0.2	–	0.2	
			2.70 ≤ V <sub>CC</sub> ≤ 3.60	–	0.2	–	0.2	
		I <sub>OL</sub> = 2mA	1.10 ≤ V <sub>CC</sub> ≤ 1.30	–	0.25 x V <sub>CC</sub>	–	0.25 x V <sub>CC</sub>	
		I <sub>OL</sub> = 4mA	1.40 ≤ V <sub>CC</sub> ≤ 1.60	–	0.25 x V <sub>CC</sub>	–	0.25 x V <sub>CC</sub>	
		I <sub>OL</sub> = 6mA	1.65 ≤ V <sub>CC</sub> ≤ 1.95	–	0.3	–	0.3	
		I <sub>OL</sub> = 12mA	2.30 ≤ V <sub>CC</sub> < 2.70	–	0.4	–	0.4	
			2.70 ≤ V <sub>CC</sub> ≤ 3.60	–	0.4	–	0.4	
		I <sub>OL</sub> = 18mA	2.30 ≤ V <sub>CC</sub> < 2.70	–	0.6	–	0.6	
			2.70 ≤ V <sub>CC</sub> ≤ 3.60	–	0.4	–	0.4	
		I <sub>OL</sub> = 24mA	2.70 ≤ V <sub>CC</sub> ≤ 3.60	–	0.55	–	0.55	
I <sub>IN</sub>	Input Leakage Current	0 ≤ V <sub>I</sub> ≤ 3.6V	0.90 to 3.60	–	±0.1	–	±0.5	µA
I <sub>OFF</sub>	Power Off Leakage Current	0 ≤ (V <sub>I</sub> , V <sub>O</sub> ) ≤ 3.6V	0	–	0.5	–	0.5	µA
I <sub>CC</sub>	Quiescent Supply Current	V <sub>I</sub> = V <sub>CC</sub> or GND	0.90 to 3.60	–	0.9	–	0.9	µA
		V <sub>CC</sub> ≤ V <sub>I</sub> ≤ 3.6V	0.90 to 3.60	–	–	–	±0.9	

### AC Electrical Characteristics

Symbol	Parameter	Conditions	V <sub>CC</sub> (V)	T <sub>A</sub> =					Units	Figure Number
				+25°C			-40°C to +85°C			
				Min.	Typ.	Max.	Min.	Max.		
t <sub>PZL</sub> , t <sub>PLZ</sub>	Propagation Delay	C <sub>L</sub> = 15pF, R <sub>U</sub> = R <sub>D</sub> 1MΩ	0.90		13				ns	Figure 1 Figure 2
			1.10 ≤ V <sub>CC</sub> ≤ 1.30	2.0	6.0	15.0	1.0	18.6		
		C <sub>L</sub> = 15pF, R <sub>U</sub> = R <sub>D</sub> 2kΩ	1.40 ≤ V <sub>CC</sub> ≤ 1.60	1.0	3.2	8.7	1.0	9.7		
			C <sub>L</sub> = 30pF, R <sub>U</sub> = R <sub>D</sub> 500Ω	1.65 ≤ V <sub>CC</sub> ≤ 1.95	1.0	2.0	6.0	1.0		6.8
				2.30 ≤ V <sub>CC</sub> < 2.70	0.7	1.2	3.6	0.6		4.7
		2.70 ≤ V <sub>CC</sub> ≤ 3.60	0.5	1.0	3.3	0.4	4.0			
C <sub>IN</sub>	Input Capacitance		0	-	2.0	-	-	-	pF	
C <sub>OUT</sub>	Output Capacitance		0	-	6.5	-	-	-	pF	
C <sub>PD</sub>	Power Dissipation Capacitance	V <sub>I</sub> = 0V or V <sub>CC</sub> , f = 10MHz	0.90 to 3.60	-	10	-	-	-	pF	

### AC Loading and Waveforms

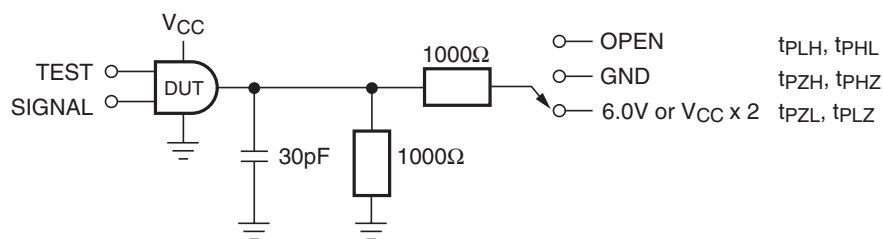

Figure 1. AC Test Circuit

Test	Switch
t <sub>PZL</sub> , t <sub>PLZ</sub>	6V at V <sub>CC</sub> = 3.3 ± 0.3V; V <sub>CC</sub> × 2 at V <sub>CC</sub> = 0.9V – 2.7V

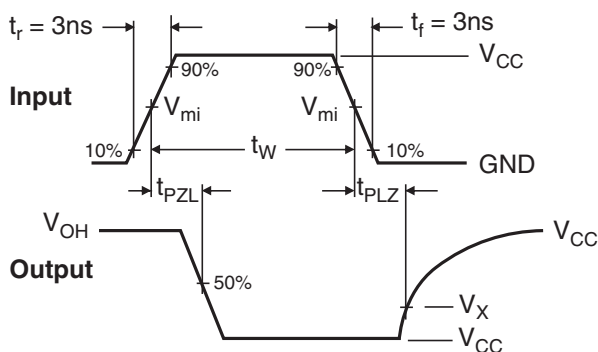

Figure 2. Waveform for Inverting and Non-Inverting Functions

Symbol	V <sub>CC</sub>					
	3.3V ± 0.3V	2.5V ± 0.2V	1.8V ± 0.15V	1.5V ± 0.1V	1.2V ± 0.1V	0.9V
V <sub>mi</sub>	1.5V	V <sub>CC</sub> /2	V <sub>CC</sub> /2	V <sub>CC</sub> /2	V <sub>CC</sub> /2	V <sub>CC</sub> /2
V <sub>x</sub>	V <sub>OL</sub> + 0.3V	V <sub>OL</sub> + 0.15V	V <sub>OL</sub> + 0.15V	V <sub>OL</sub> + 0.1V	V <sub>OL</sub> + 0.1V	V <sub>OL</sub> + 0.1V

## Tape and Reel Specification

### Tape Format for SC70

Package Designator	Tape Section	Number Cavities	Cavity Status	Cover Tape Status
P6X	Leader (Start End)	125 (typ)	Empty	Sealed
	Carrier	3000	Filled	Sealed
	Trailer (Hub End)	75 (typ)	Empty	Sealed

### Tape Dimension inches (millimeters)

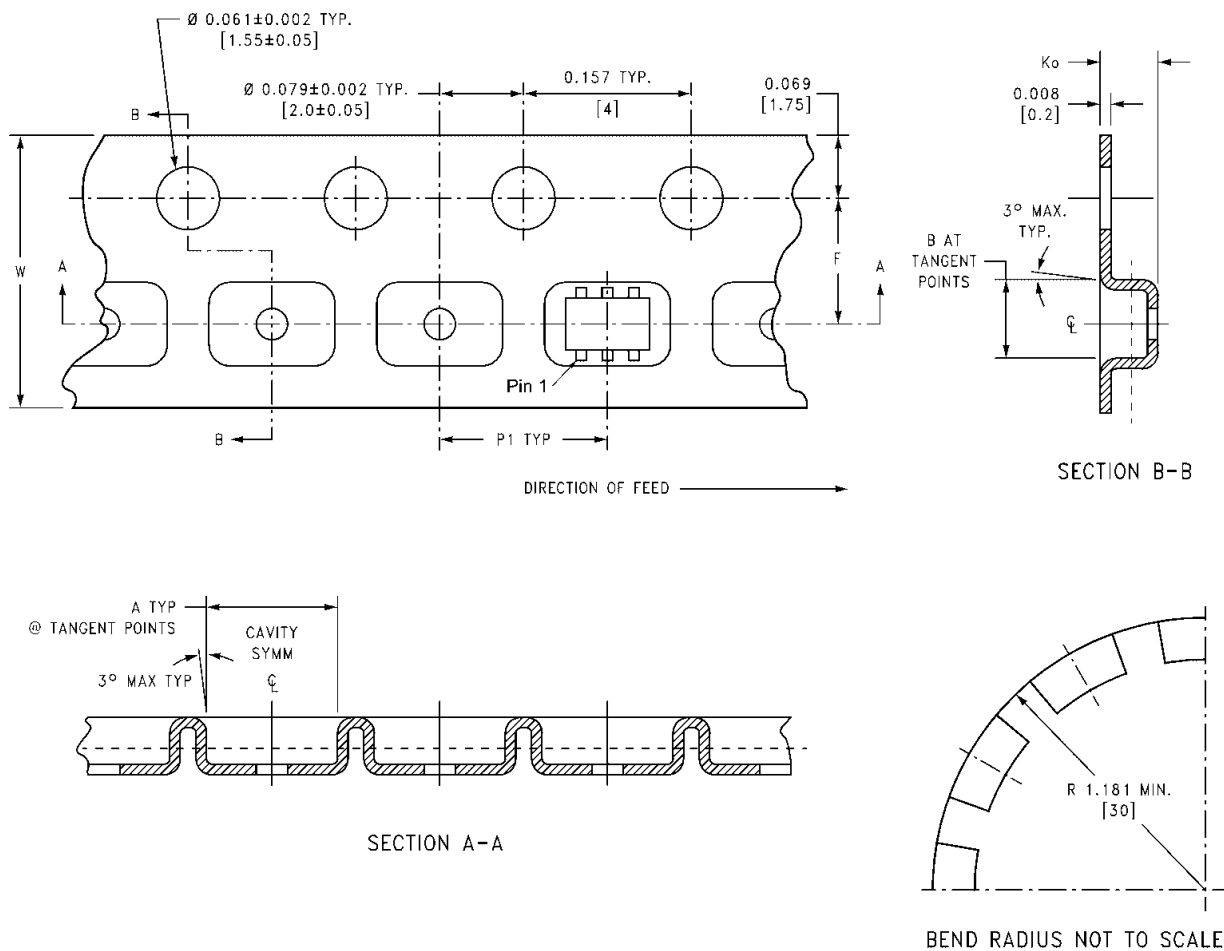

## Tape and Reel Specification (Continued)

### Tape Format for MicroPak

Package Designator	Tape Section	Number Cavities	Cavity Status	Cover Tape Status
L6X	Leader (Start End)	125 (typ)	Empty	Sealed
	Carrier	5000	Filled	Sealed
	Trailer (Hub End)	75 (typ)	Empty	Sealed

### Tape Dimension millimeters

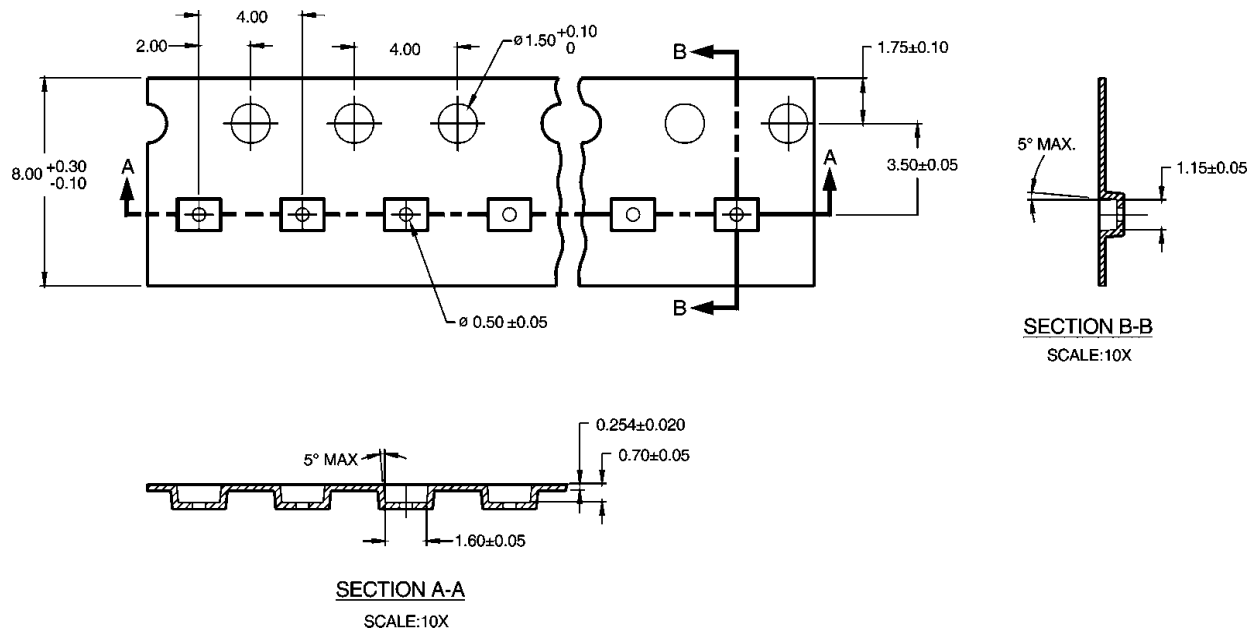

**Tape and Reel Specification** (Continued)

**Reel Dimension for MicroPak** inches (millimeters)

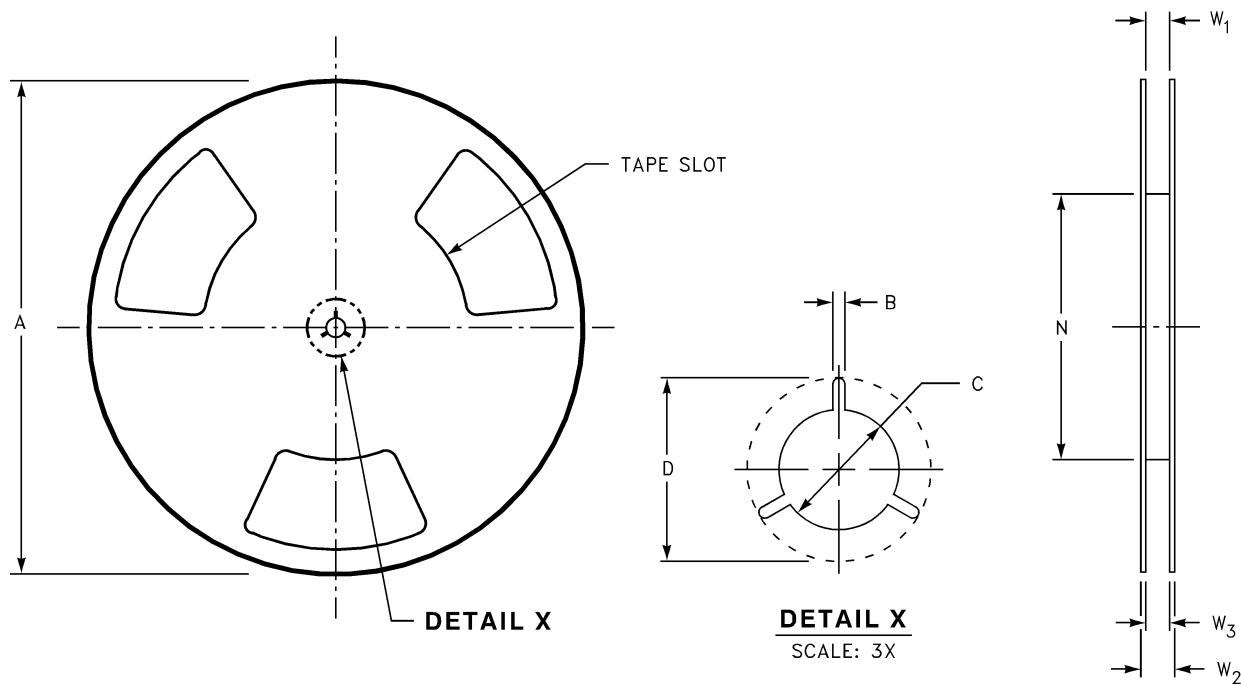

Tape Size	A	B	C	D	N	W1	W2	W3
8mm	7.0 (177.8)	0.059 (1.50)	0.512 (13.00)	0.795 (20.20)	2.165 (55.00)	0.331 + 0.059/-0.000 (8.40 + 1.50/-0.00)	0.567 (14.40)	W1 + 0.078/-0.039 (W1 + 2.00/-1.00)



**Physical Dimensions** millimeters unless otherwise noted

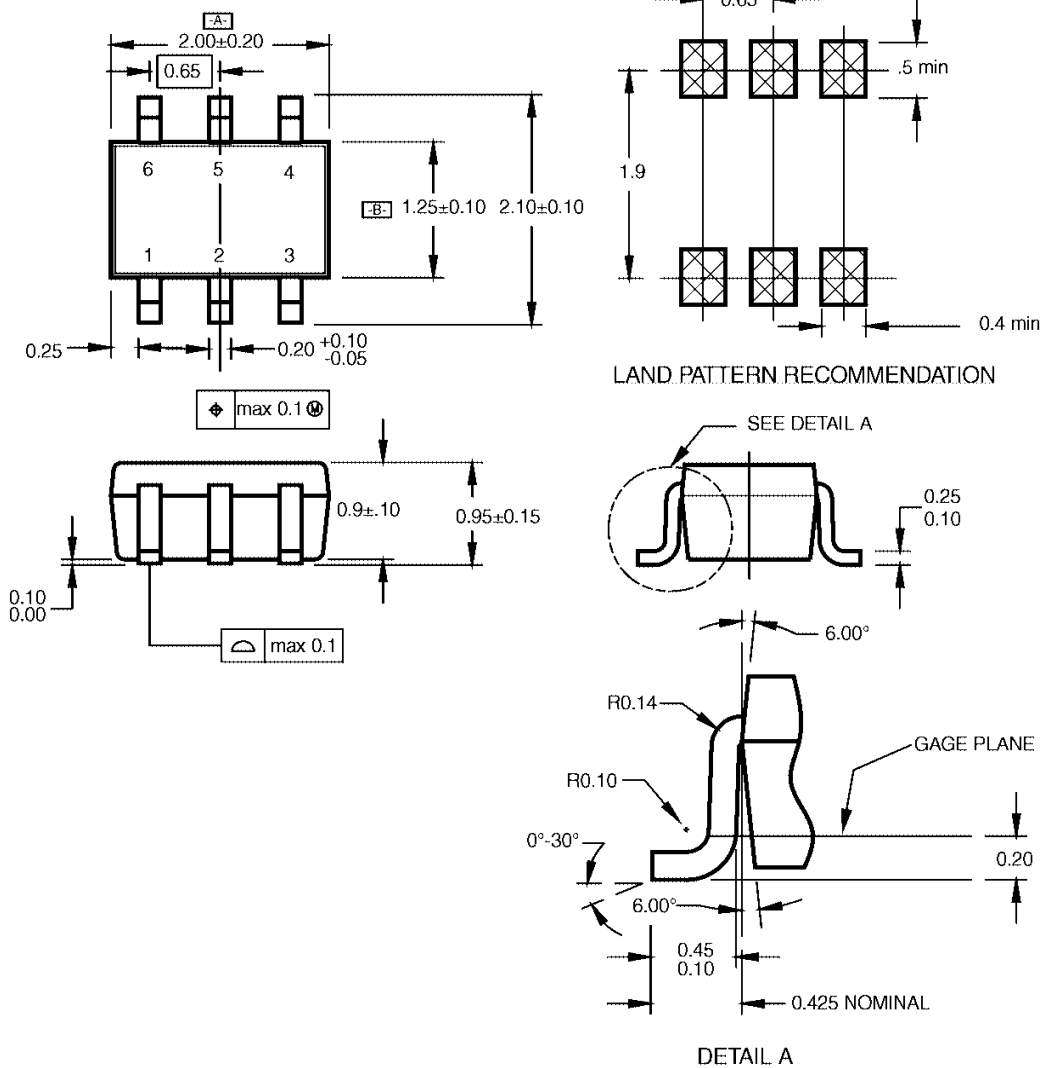

**NOTES:**

- A. CONFORMS TO EIAJ REGISTERED OUTLINE DRAWING SC88.
- B. DIMENSIONS DO NOT INCLUDE BURRS OR MOLD FLASH.
- C. DIMENSIONS ARE IN MILLIMETERS.

MAA06ARevC

**6-Lead SC70, EIAJ SC88, 1.25mm Wide  
Package Number MAA06A**

**Physical Dimensions** millimeters unless otherwise noted (Continued)

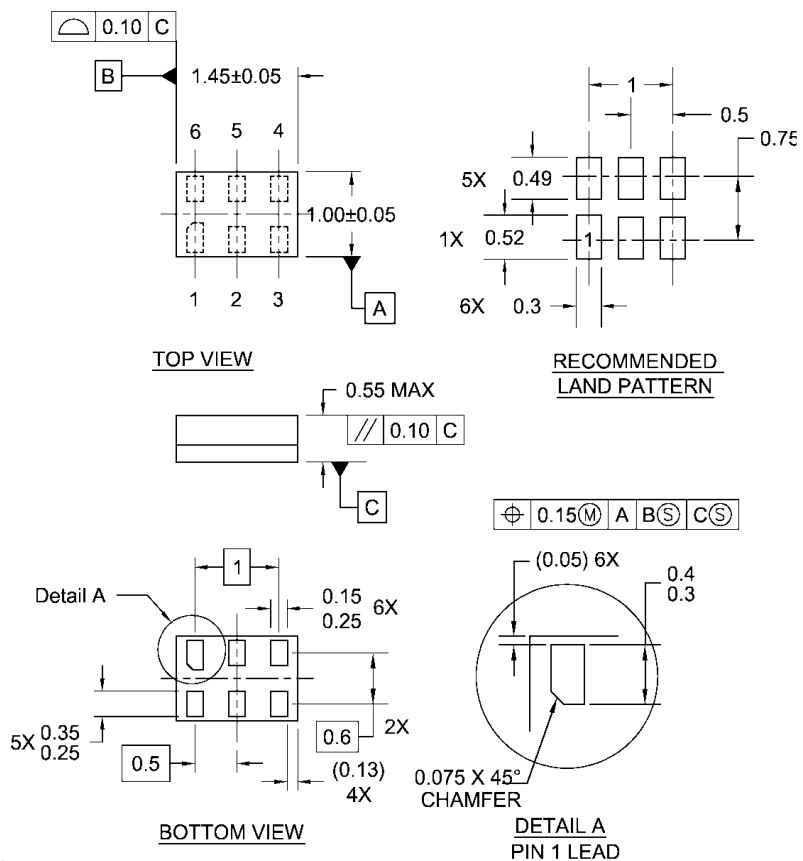

Notes:

1. JEDEC PACKAGE REGISTRATION IS ANTICIPATED
2. DIMENSIONS ARE IN MILLIMETERS
3. DRAWING CONFORMS TO ASME Y14.5M-1994

MAC06ARevB

**6-Lead MicroPak, 1.0mm Wide  
Package Number MAC06A**

## TRADEMARKS

The following are registered and unregistered trademarks Fairchild Semiconductor owns or is authorized to use and is not intended to be an exhaustive list of all such trademarks.

ACEx™	FAST®	ISOPLANAR™	PowerEdge™	SuperFET™
ActiveArray™	FASTr™	LittleFET™	PowerSaver™	SuperSOT™-3
Bottomless™	FPST™	MICROCOUPLER™	PowerTrench®	SuperSOT™-6
Build it Now™	FRFET™	MicroFET™	QFET®	SuperSOT™-8
CoolFET™	GlobalOptoisolator™	MicroPak™	QS™	SyncFET™
CROSSVOLT™	GTO™	MICROWIRE™	QT Optoelectronics™	TCM™
DOME™	HiSeC™	MSX™	Quiet Series™	TinyLogic®
EcoSPARK™	I <sup>2</sup> C™	MSXPro™	RapidConfigure™	TINYOPTO™
E <sup>2</sup> CMOS™	i-Lo™	OCX™	RapidConnect™	TruTranslation™
EnSigna™	ImpliedDisconnect™	OCXPro™	μSerDes™	UHC™
FACT™	IntelliMAX™	OPTOLOGIC®	ScalarPump™	UniFET™
FACT Quiet Series™		OPTOPLANAR™	SILENT SWITCHER®	UltraFET®
Across the board. Around the world.™		PACMAN™	SMART START™	VCX™
The Power Franchise®		POP™	SPM™	Wire™
Programmable Active Droop™		Power247™	Stealth™	

## DISCLAIMER

FAIRCHILD SEMICONDUCTOR RESERVES THE RIGHT TO MAKE CHANGES WITHOUT FURTHER NOTICE TO ANY PRODUCTS HEREIN TO IMPROVE RELIABILITY, FUNCTION OR DESIGN. FAIRCHILD DOES NOT ASSUME ANY LIABILITY ARISING OUT OF THE APPLICATION OR USE OF ANY PRODUCT OR CIRCUIT DESCRIBED HEREIN; NEITHER DOES IT CONVEY ANY LICENSE UNDER ITS PATENT RIGHTS, NOR THE RIGHTS OF OTHERS. THESE SPECIFICATIONS DO NOT EXPAND THE TERMS OF FAIRCHILD'S WORLDWIDE TERMS AND CONDITIONS, SPECIFICALLY THE WARRANTY THEREIN, WHICH COVERS THESE PRODUCTS.

## LIFE SUPPORT POLICY

FAIRCHILD'S PRODUCTS ARE NOT AUTHORIZED FOR USE AS CRITICAL COMPONENTS IN LIFE SUPPORT DEVICES OR SYSTEMS WITHOUT THE EXPRESS WRITTEN APPROVAL OF FAIRCHILD SEMICONDUCTOR CORPORATION.

As used herein:

- Life support devices or systems are devices or systems which, (a) are intended for surgical implant into the body, or (b) support or sustain life, or (c) whose failure to perform when properly used in accordance with instructions for use provided in the labeling, can be reasonably expected to result in significant injury to the user.
- A critical component is any component of a life support device or system whose failure to perform can be reasonably expected to cause the failure of the life support device or system, or to affect its safety or effectiveness.

## PRODUCT STATUS DEFINITIONS

### Definition of Terms

Datasheet Identification	Product Status	Definition
Advance Information	Formative or In Design	This datasheet contains the design specifications for product development. Specifications may change in any manner without notice.
Preliminary	First Production	This datasheet contains preliminary data, and supplementary data will be published at a later date. Fairchild Semiconductor reserves the right to make changes at any time without notice in order to improve design.
No Identification Needed	Full Production	This datasheet contains final specifications. Fairchild Semiconductor reserves the right to make changes at any time without notice in order to improve design.
Obsolete	Not In Production	This datasheet contains specifications on a product that has been discontinued by Fairchild semiconductor. The datasheet is printed for reference information only.

Rev. 119